

No. 622,906.

Patented Apr. 11, 1899.

N. M. WATSON.

CUTTER FOR CUTTING METALLIC PACKING.

(Application filed May 20, 1898.)

(No Model.)

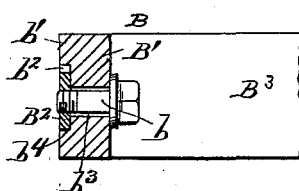
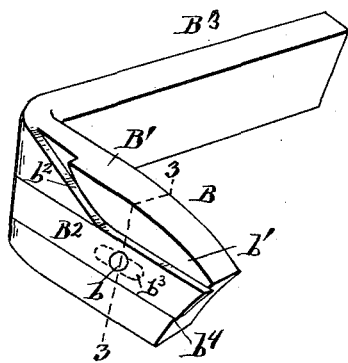
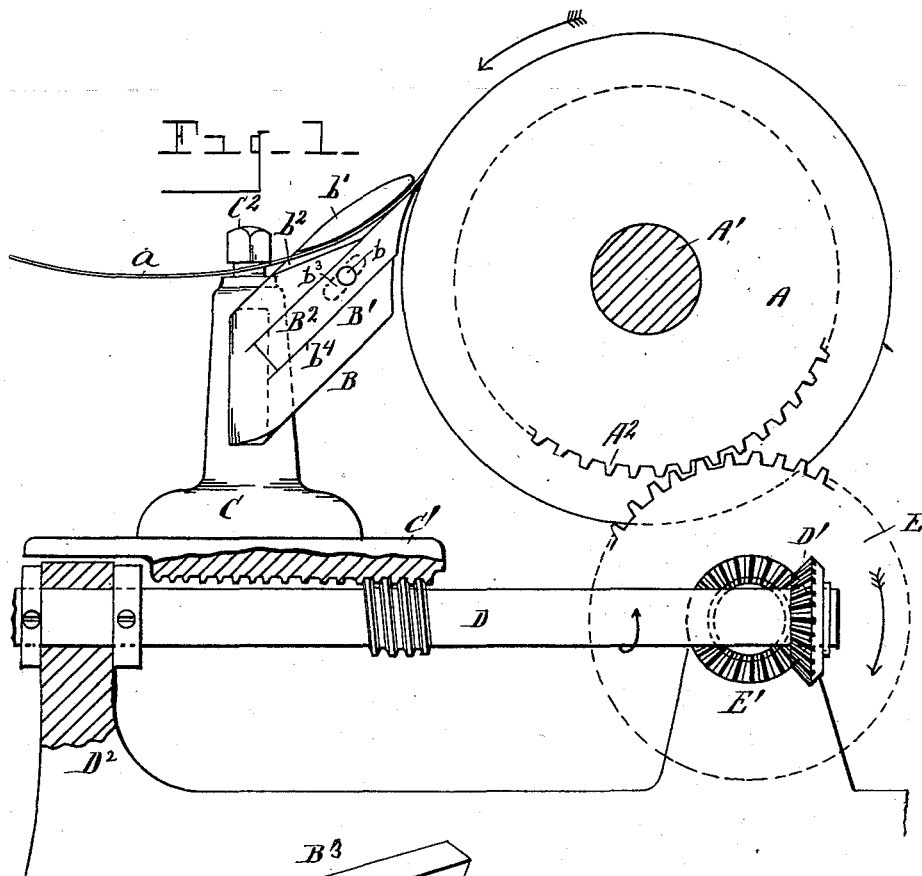

WITNESSES.

O. B. Paruziger.
Mary Lickay.

INVENTOR.

Nelson M. Watson
By Newell S. Wright
 His Attorney

UNITED STATES PATENT OFFICE.

NELSON M. WATSON, OF DETROIT, MICHIGAN, ASSIGNOR TO JEFFERSON T. WING, OF SAME PLACE.

CUTTER FOR CUTTING METALLIC PACKING.

SPECIFICATION forming part of Letters Patent No. 622,906, dated April 11, 1899.

Application filed May 20, 1898. Serial No. 681,193. (No model.)

To all whom it may concern:

Be it known that I, NELSON M. WATSON, a citizen of the United States, residing at Detroit, county of Wayne, State of Michigan, have invented a certain new and useful Improvement in Cutters for Cutting Metallic Packing; and I declare the following to be a full, clear, and exact description of the invention, such as will enable others skilled in the art to which it appertains to make and use the same, reference being had to the accompanying drawings, which form a part of this specification.

My invention has for its object a novel cutter for cutting metallic packing; and it consists of the devices hereinafter described and claimed, and illustrated in the accompanying drawings, in which—

Figure 1 is a view in side elevation, showing parts of a lathe with my improved cutter attached thereto and in position to cut a strip of metallic packing from a metal disk or cylinder. Fig. 2 is a detail view in perspective of the cutter. Fig. 3 is a view in section on the line 3 3, Fig. 2.

My invention is designed to provide a cutter to cut a metallic packing formed of long, continuous, flat, and narrow strips of antifriction metal, a desired number of such strips being assembled in a rope form to constitute a packing for various purposes, also to form gaskets and for analogous uses. For this purpose my invention contemplates a cutter for cutting a long continuous strip of antifriction or other metal from a disk or cylinder, the cutter being arranged to feed straight inward toward the center of said disk or cylinder, so as to cut the strips in a long continuous flat form. It will be obvious that if the cutter traveled horizontally across the disk or cylinder it would cut a strip or shaving which would curl or coil, and which I aim to prevent, and to secure the individual strips for the packing, as heretofore stated, in a long flat continuous strip which will not coil or curl in its normal condition.

In the accompanying drawings I have shown my improved cutter in connection with suitable mechanism for operating the same. Accordingly, in carrying out my invention, A represents a disk or cylinder of suitable metal

from which the individual continuous strips are to be cut, such a strip being indicated at *a*. This disk or cylinder is rotatable upon a shaft A' in any suitable manner.

B indicates my improved cutting-tool mounted upon a tool standard or support C, said standard being carried by a rack C', meshing with a worm D. The worm is driven by a gear E, meshing with a gear A² upon the shaft A'. Upon the shaft of the gear E is a bevel-gear E', meshing with a bevel-gear D' upon the worm D. By this construction it will be apparent that as the disk or cylinder A rotates the worm will rotate correspondingly and cause a corresponding travel of the cutter inward toward the center of said disk or cylinder.

My improved cutter is formed with any suitable body, (indicated at B',) having a suitable cutter-blade B² secured thereupon. The cutter-body may be provided with an arm B³, whereby the cutter is engaged upon the support C. The cutter-blade B² may be secured in place by means of a bolt *b*. The cutter-body is provided with a flange or shoulder (indicated at *b'*) adjacent to one edge of the blade B², but leaving a channel (indicated at *b*²) between said shoulder and the adjacent edge of the cutter-blade, through which the strip *a*, which has been cut by the edge of the cutter-blade, may pass, the shoulder *b'* guiding the strip through said channel and upon a reel or other suitable device for carrying the strip. The shoulder *b'* preferably projects over the upper edge of the blade B², as shown. The body B' of the cutter is preferably constructed with an elongated orifice at *b*³, as indicated in dotted lines in Fig. 2, so that the blade may be adjusted to compensate for any wear in grinding and so that the cutting edge of the blade may be set or adjusted as required. The channel *b*² preferably projects rearward from the cutting edge of the blade longitudinally of the blade for a suitable distance, as in Fig. 2, the channel then projecting upward, as shown.

I would have it understood that I do not limit myself to any special means for rotating the disk or cylinder A or for advancing the cutter B to the work directly toward the center of the disk or cylinder. The cutter

may be held in the support C in any suitable manner, as by a screw C².

D² represents any suitable support.

The cutter is immovable in operation longitudinally of the disk A, the cutter being movable inward toward the center of said disk, so as to cut the disk peripherally straight in toward the center to form an unconvoluted strip. It will be readily understood that a strip so formed will be much stronger than were the cutter movable longitudinally along the disk, thereby cutting a coiled or convoluted strip. It will be readily understood that the channel b^2 is in the nature of a guide-channel through which the strip is directed after being cut from the disk. The body is recessed on one of its faces, as shown at b^4 , to receive the cutter-blade, said recesses being extended laterally at one side of the blade to communicate with the channel b^2 .

The gear E may be driven from any suitable source of power.

The recess b^4 of the body of the cutter extends longitudinally of said body, as well as the cutter-blade located therein, while the channel b^2 also projects rearwardly longitudinally of the cutter-body and parallel with the upper lateral edge of the cutter-blade. I do not, however, claim as new the mechanism for operating the cutter.

What I claim as my invention is—

1. A cutter for the purpose described, having in combination a body recessed upon one of its lateral faces, longitudinally of said body, and a cutter-blade engaged in said recess longitudinally of said body, said body provided with an additional guide-channel adjacent to one of the marginal edges of said blade upon

the same face thereof as said recess through which a shaving or strip severed by the cutter-blade may pass, and with a flange or shoulder adjacent to said guide-channel, said flange or shoulder projecting over the adjacent edge of the blade, said guide-channel communicating with said recess at its forward end and extending at right angles to the cutting edge of the blade parallel with one of the marginal edges of the blade from the cutting edge of the blade rearward longitudinally of the body and then opening upward through said body, substantially as set forth.

2. A cutter for the purpose described, having in combination a body provided with a recess b^4 longitudinally of said body to receive a cutter-blade, and constructed to be secured to a suitable support, and a cutter-blade engaged in said recess longitudinally of said body, said body provided with an additional guide-channel b^2 adjacent to one of the marginal edges of said blade through which a shaving or strip severed by a cutter-blade may pass, said guide-channel communicating with said recess at the forward end thereof and extending at right angles to the cutting edge of the blade parallel with one of the marginal edges of the cutter-blade from the cutting edge of the blade rearward longitudinally of the body, and then diverging from said recess and opening in an upward direction through said body, substantially as set forth.

In testimony whereof I sign this specification in the presence of two witnesses.

NELSON M. WATSON.

Witnesses:

JEFFERSON T. WING,
N. S. WRIGHT.